

CONSUMER INFORMATION ON:

- **Cargo Weight Rating**
- **Center of Gravity**

**2019
RAM 1500**

Camper Application

For additional copies, reference www.mopar.com/en-us/care/owners-manual

CONSUMER INFORMATION: TRUCK-CAMPER LOADING

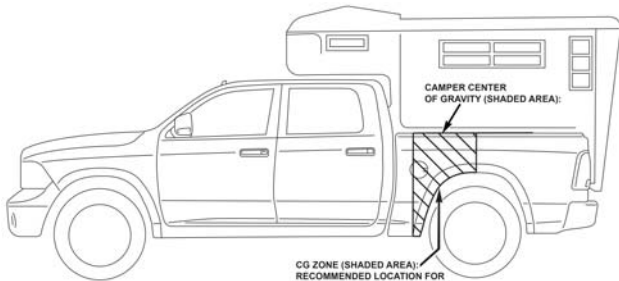

0670140307US

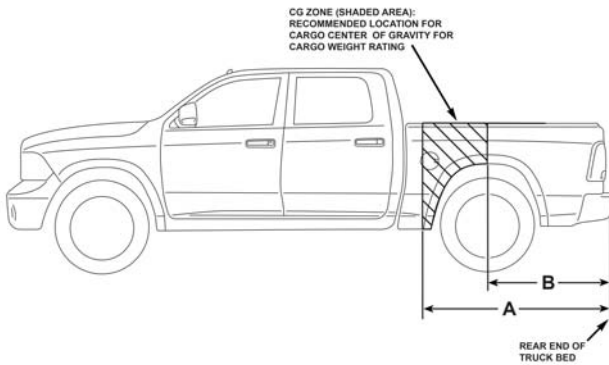

0670140308US

The tables on the following pages designate the Cargo Weight Rating and the Center of Gravity Zone for each vehicle listed.

- **CARGO WEIGHT RATING (CWR)** for a given truck model is the cargo capacity, in pounds, excluding the weight of occupants in the cab of the vehicle.
- **CENTER OF GRAVITY (CG) ZONE** is the area BETWEEN the forward limit dimension "A", and the rearward limit dimension "B" ... both measured in inches from the rear end of the truck bed or pickup box (see illustration above).
- When the truck is used to carry a slide-in camper, the total cargo load of the truck consists of the manufacturer's camper weight figure, the weight of installed additional camper equipment not included in the manufacturer's camper weight figure, the weight of camper cargo, and the weight of passengers in the camper. The total cargo load should not exceed the truck's cargo weight rating and the camper's center of gravity should fall within the truck's recommended center of gravity zone when installed.
- Secure loose items to prevent weight shifts that could affect the balance of your vehicle. When the truck camper is loaded, drive to a scale and weigh on the front and on the rear wheels separately to determine axle loads. Individual axle loads should not exceed either of the gross axle weight ratings (GAWR). The total of the axle loads should not exceed the gross vehicle weight rating (GVWR). These ratings are given on the vehicle certification label that is located on the left side of the vehicle, normally the dash, hinge pillar, door latch post, or door edge next to the driver. If weight ratings are exceeded, move or remove items to bring all weights below the ratings.

USING THE TABLES:

- At the top of each page are descriptions of the truck models; wheelbase; type of cab; size of pickup box; style of seats; and the gross vehicle weight rating (GVWR) applicable to the truck.
- Sub-headings classify the CWR and CG zone dimensions based on engine types available. Under the “options” column, items of optional equipment (related to the vehicle’s intended use) are listed in various combinations, indicating their influence on CWR figures.
- When reading the tables, you will notice that, as more optional equipment is added to the base vehicle (reading down from line 1 to line 8), the CWR is decreased due to the additional weight of the options. At the same time, the size of the CG zone changes due to the LOCATION of the added weight.

INSTALLING THE CAMPER:

- The center of gravity (CG) of the loaded camper, as determined and marked by the camper manufacturer, must fall within the CG zone of the truck (see illustration above).
- The total weight of the fully-equipped camper, furnished by the camper manufacturer, should not exceed the CWR of the truck. After the camper and auxiliary equipment is installed, proper loading should be verified on an accurate truck scale before putting the vehicle into service.
- Be sure the gross vehicle weight rating (GVWR) of the truck is not exceeded and that the loading on front and rear axle systems does not exceed their respective gross axle weight ratings (GAWR).

NOTE: GVWR and GAWR data for the truck appears on the Safety Certification label, located on the door-latch post, on the driver’s side.

Model	Ram 1500 4X2 SLT, Big Horn, Lone Star, Lone Star Silver 3.6L V6 Engine	
Cab (Box) Seats	Reg Cab 6'4" Box Bucket	
GVWR (lbs)	6025	
	<u>BUCKET</u>	
	"A"	"B"
CWR (lbs)	(in/cm)	(in/cm)
991.12	75.0 / 190.5	25.0 / 63.5

Model	Ram 1500 4X2 SLT, Big Horn, Lone Star, Lone Star Silver 5.7L V8 Engine	
Cab (Box) Seats	Reg Cab 6'4" Box Bench	
GVWR (lbs)	6350	
	<u>BENCH</u>	
	"A"	"B"
CWR (lbs)	(in/cm)	(in/cm)
918.17	75.0 / 190.5	25.0 / 63.5

Model	Ram 1500 4X2 SLT, Big Horn, Lone Star, Lone Star Silver 5.7L V8 Engine	
Cab (Box) Seats	Reg Cab 6'4" Box Bucket	
GVWR (lbs)	6350	
	<u>BUCKET</u>	
	"A"	"B"
CWR (lbs)	(in/cm)	(in/cm)
1063.77	75.0 / 190.5	25.0 / 63.5

Model	Ram 1500 4X2 SLT, Big Horn, Lone Star, Lone Star Silver 3.6L V6 Engine	
Cab (Box) Seats	Reg Cab 8' Box Bench	
GVWR (lbs)	6600	
	<u>BENCH</u>	
	"A"	"B"
CWR (lbs)	(in/cm)	(in/cm)
1141.65	75.0 / 190.5	25.0 / 63.5

Model	Ram 1500 4X2 SLT, Big Horn, Lone Star, Lone Star Silver 3.6L V6 Engine	
Cab (Box) Seats	Reg Cab 8' Box Bucket	
GVWR (lbs)	6600	
	<u>BUCKET</u>	
	<u>"A"</u>	<u>"B"</u>
CWR (lbs)	(in/cm)	(in/cm)
1298.21	75.0 / 190.5	25.0 / 63.5

Model	Ram 1500 4X2 SLT, Big Horn, Lone Star, Lone Star Silver 3.0L DIE Engine	
Cab (Box) Seats	Reg Cab 8' Box Bucket	
GVWR (lbs)	6600	
	<u>BUCKET</u>	
	<u>"A"</u>	<u>"B"</u>
CWR (lbs)	(in/cm)	(in/cm)
931.29	75.0 / 190.5	25.0 / 63.5

Model	Ram 1500 4X2 SLT, Big Horn, Lone Star, Lone Star Silver 5.7L V8 Engine	
Cab (Box) Seats	Reg Cab 8' Box Bench	
GVWR (lbs)	6600	
	<u>BENCH</u>	
	<u>"A"</u>	<u>"B"</u>
CWR (lbs)	(in/cm)	(in/cm)
1006.14	75.0 / 190.5	25.0 / 63.5

Model	Ram 1500 4X2 SLT, Big Horn, Lone Star, Lone Star Silver 5.7L V8 Engine	
Cab (Box) Seats	Reg Cab 8' Box Bucket	
GVWR (lbs)	6600	
	<u>BUCKET</u>	
	<u>"A"</u>	<u>"B"</u>
CWR (lbs)	(in/cm)	(in/cm)
1151.74	75.0 / 190.5	25.0 / 63.5

Model	Ram 1500 4X2 Tradesman, Express	
	3.6L V6 Engine	
Cab (Box) Seats	Reg Cab 6'4" Box Bench	
GVWR (lbs)	6025	
	<u>BENCH</u>	
	"A"	"B"
CWR (lbs)	(in/cm)	(in/cm)
911.82	75.0 / 190.5	25.0 / 63.5

Model	Ram 1500 4X2 Tradesman, Express	
	5.7L V8 Engine	
Cab (Box) Seats	Reg Cab 6'4" Box Bench	
GVWR (lbs)	6350	
	<u>BENCH</u>	
	"A"	"B"
CWR (lbs)	(in/cm)	(in/cm)
980.80	75.0 / 190.5	25.0 / 63.5

Model	Ram 1500 4X2 Tradesman, Express	
	3.6L V6 Engine	
Cab (Box) Seats	Reg Cab 8' Box Bench	
GVWR (lbs)	6600	
	<u>BENCH</u>	
	"A"	"B"
CWR (lbs)	(in/cm)	(in/cm)
1204.86	75.0 / 190.5	25.0 / 63.5

Model	Ram 1500 4X2 Tradesman, Express	
	5.7L V8 Engine	
Cab (Box) Seats	Reg Cab 8' Box Bench	
GVWR (lbs)	6600	
	<u>BENCH</u>	
	"A"	"B"
CWR (lbs)	(in/cm)	(in/cm)
1049.63	75.0 / 190.5	25.0 / 63.5

Model	Ram 1500 4X4 SLT, Big Horn, Lone Star, Lone Star Silver	
	3.6L V6 Engine	
Cab (Box) Seats	Reg Cab 6'4" Box Bucket	
GVWR (lbs)	6300	
	<u>BUCKET</u>	
	"A"	"B"
CWR (lbs)	(in/cm)	(in/cm)
1007.97	75.0 / 190.5	25.0 / 63.5

Model	Ram 1500 4X4 SLT, Big Horn, Lone Star, Lone Star Silver	
	3.6L V6 Engine	
Cab (Box) Seats	Reg Cab 8' Box Bench	
GVWR (lbs)	6600	
	<u>BENCH</u>	
	"A"	"B"
CWR (lbs)	(in/cm)	(in/cm)
929.74	75.0 / 190.5	25.0 / 63.5

Model	Ram 1500 4X4 SLT, Big Horn, Lone Star, Lone Star Silver	
	3.6L V6 Engine	
Cab (Box) Seats	Reg Cab 8' Box Bucket	
GVWR (lbs)	6600	
	<u>BUCKET</u>	
	"A"	"B"
CWR (lbs)	(in/cm)	(in/cm)
1075.34	75.0 / 190.5	25.0 / 63.5

Model	Ram 1500 4X4 SLT, Big Horn, Lone Star, Lone Star Silver	
	5.7L V8 Engine	
Cab (Box) Seats	Reg Cab 8' Box Bucket	
GVWR (lbs)	6600	
	<u>BUCKET</u>	
	"A"	"B"
CWR (lbs)	(in/cm)	(in/cm)
966.19	75.0 / 190.5	25.0 / 63.5

Model Ram 1500 4X4 Tradesman, Express

3.6L V6 Engine

Cab (Box) Seats Reg Cab 8' Box Bench

GVWR (lbs) 6600

BENCH

"A"

"B"

CWR (lbs)

(in/cm)

(in/cm)

1008.40

75.0 / 190.5

25.0 / 63.5

